



Service

We are here for you!

Space accessibility for servicing is available in all models. This is due to the efficient technology of tilting cabs for essential service and repairs. Both the cabin and the platform can be opened hydraulically. Harvester with slope leveling on all machine models. Thanks to the generous space provided and the clear arrangement of all components, service or repair work can be carried out ergonomically, quickly and safely.

Neuson Forest GmbH
Freiling Str. 40, 4614 Marchtrenk, Austria
Tel. +43 (0) 7243/214 00-00
mail office@neuson-forest.com

No liability for printing errors.

Please see our T's & C's at: www.neuson-forest.com

Find us on Facebook: facebook.com/Neuson.Forest



Harvester with slope leveling

204HVT

The new 20t universal machine

from thinning to final felling



neuson
FOREST

Easy Drive
Easy Handover



Perfectly Ergonomic:
A simple push of a button is enough
to switch between foot and joystick
control for the operation of the tracks.
No more tired legs when moving the
machine long distances!





Intuitive Control

Everything at a glance.
Everything under control.

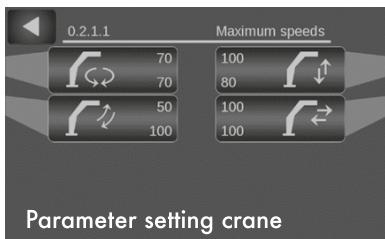

Parameter setting crane

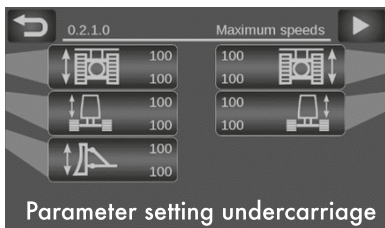

Parameter setting undercarriage

Everything at a glance:
The main menu

Thanks to the electrical pilot control and the XCrane control from Technion, the machine is easily adaptable to the needs of the operator.

You can choose from 5 individually adjustable driver profiles.



Customized Track

From the swamp to the steep slope

Thanks to the various chain options, the machine can be adapted to your application in a very short time. And with the practical quick-changing bolt, the chain can be changed in no time.



Single Grouser

Perfect for steep slopes.
Available from 500 - 600mm

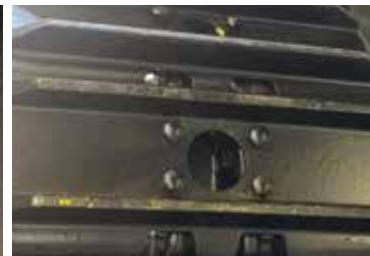

Double Grouser

The universal chain.
Available 500 - 700mm



Rubber Pads

For street use.
Available from 500 - 600mm



Curved Triple Grouser

Especially for wet surfaces.
Available from 500 - 800mm

The interior of the 204HVT was re-developed in an intensive design process. The first task was: Listening. Namely to the drivers who work with our machines on a daily basis.

Based on this knowledge, we not only designed a functional work place, but also a living space.

Ergonomic Space

Work place and Living space



In this extreme environment comfort is not just a luxury, but a requirement: Fatigue free seating and hand position. Unhindered view. Pleasant temperature and extensive protection from noise and vibrations. And we went a step further by integrating a number of features that make life easier: Lots of intelligent storage space, a large cool box, a cup holder, mobile phone dock, USB ports und muchmore.

The crane can be operated easily and precisely with the STH-System: The driver has direct control of the crane. The left mini-lever controls horizontal movement, the right one controls vertical movement of the head. This intuitive handling enables fatigue-free work, high productivity and thus cost savings.

xCrane PRO



Smart Tip Handling

Ingenious Crane tip control



Auto-Levelling

Automatic balancing

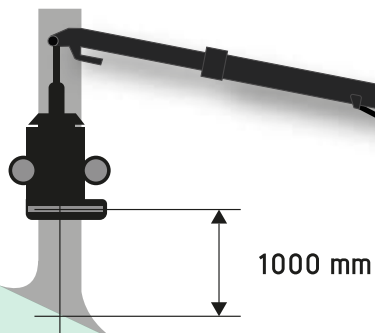

1000 mm



15°



25°



The 204HVT is equipped with a proven superstructure levelling system (Tilt). A slope compensation of 25° at the front and +/- 15° at the side enables efficient work in steep and impassable terrain.

With the auto-leveling option, the machine keeps its balance independently.

FarReach

Its all about the length

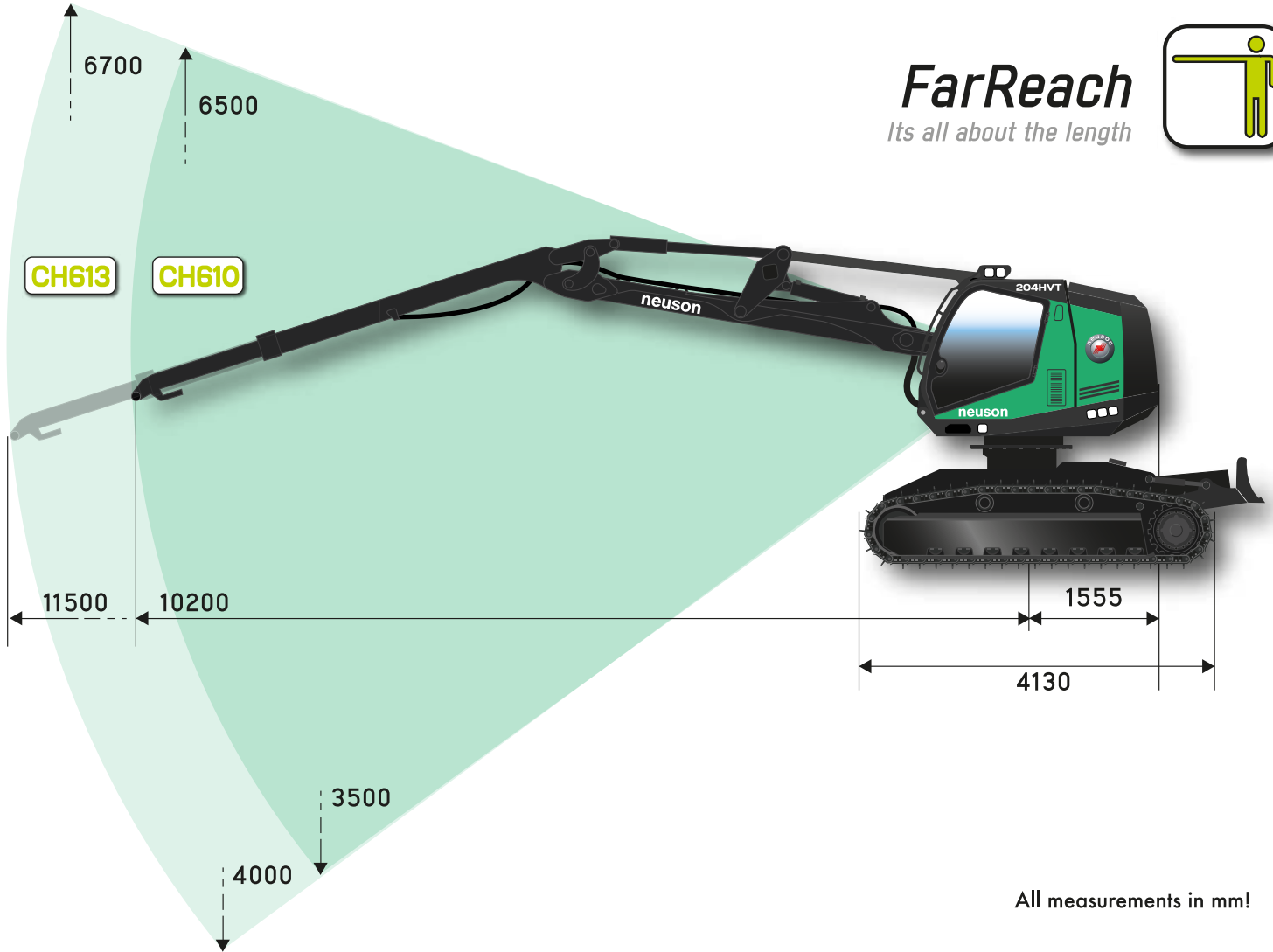

All measurements in mm!

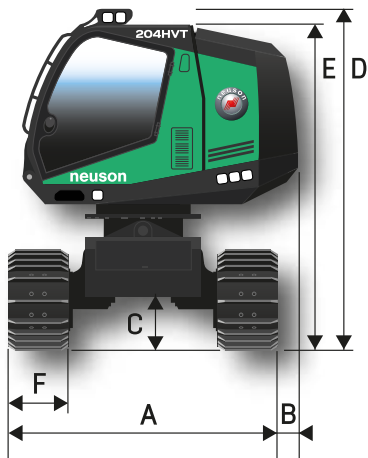

Short Tail

Short and sweet

The minimal overhang of the stern allows maneuvering in narrow fields and is very gentle on crops.

All measurements in mm!

Two undercarriage options are available:

25

2.5 m undercarriage width and only 3.2 m overall height for compact transport

A	2500
B	305
C	510
D	3350
E	3200
F	550

27

2.7 m drive width and 3.4 m total height for increased stability and ground clearance

A	2700
B	205
C	610
D	3450
E	3300
F	600

Main Features

Slope compensation (Tilt): 25° at the front, +/- 15° to the side
 (Auto Levelling option) shortened tail swing radius
 Transport from 3.2m machine height
 Chassis speeds 2.1/4.4 km/h
 Upper carriage speed max. 6.5 rpm, endless swivel range
 Dead weight 20.7 t
 Swing torque 43.6 kNm (32.000 lb-ft.)
 Gradeability 30° (60%)

Crane

CH610 or CH 613 (Range: 10.2m or 11.5m) possible heads:
 AFM 55, Waratah H424, Logmax 5000D
 Smart Tip Handling (Option):
 Technion X-Crane with intelligent crane tip control.

UnderCarriage

Standard chains: 600mm as well as 550mm 1-chalieng
 2.5m or 2.7m drive width available
 Ground clearance max. 610mm
 Ground pressure 0.46 or 0.42* kg/cm2 (*with 600mm chain)
 Undercarriage traction 212 kN

Motor

6 cylinder John Deere 6068 HI550 | 6.8 l | Turbo-Diesel
 Output 163 kW | 222 hp | 1800 rpm
 Emission Level EU StageV, EPA
 Tier 4f cooling: Coolant, air charge
 400 l Diesel tank in undercarriage
 Alternator 24V | 100 A Battery 24V / 2 x 135 Ah

Hydraulics

Automatic, hydraulic reversible fan Axko-pump (50 l/min)
 Delivery rate 399 l/min | Operating pressure max. 320 bar
 Hydraulic tank 150 l
 Hydraulic filter: 2 return filters 20 µm, Option: 1 High pressure filter 10 µm

Made in Austria - Completely assembled and developed in Marchtrenk